

OZONIZATION FOR DECOLOURIZATION OF EFFLUENTS FROM DYEING PROCESSES

WEDECO Research & Development GmbH
Boschstraße 6
D-32051 Herford

0. Summary

Chlorine-based oxidation agents cause problems in industrial waste water as a result of AOX formation and the salting up of the water. In many cases, these products can be replaced by ozone oxidation. Ozone oxidation is becoming increasingly popular in the textile industry for the purpose of decolourization. In addition an AOX problem does not occur, and the COD is also reduced. By using ozone, water used in production processes and waste water can be treated in an environmentally-friendly way. The following is a description of the use of ozone technology for decolourization of industrial waste water streams from laboratory tests, field tests and industrial application.

1. Introduction

An example of an ozone application in water streams, which contain substances having a high reactivity towards ozone, is the decolourization of effluents from the textile industry. Many dyestuffs have a high reactivity towards ozone because of their unsaturated nature. [1].

A good example would be the oxidation of indigo, which is also used for the analytical determination of ozone [2, 3]. Using only minimum quantities of ozone, the reaction occurs in a matter of seconds, and, as a result of the destruction of the central carbon-carbon double bond, leads to complete decolourization, see fig. 1.

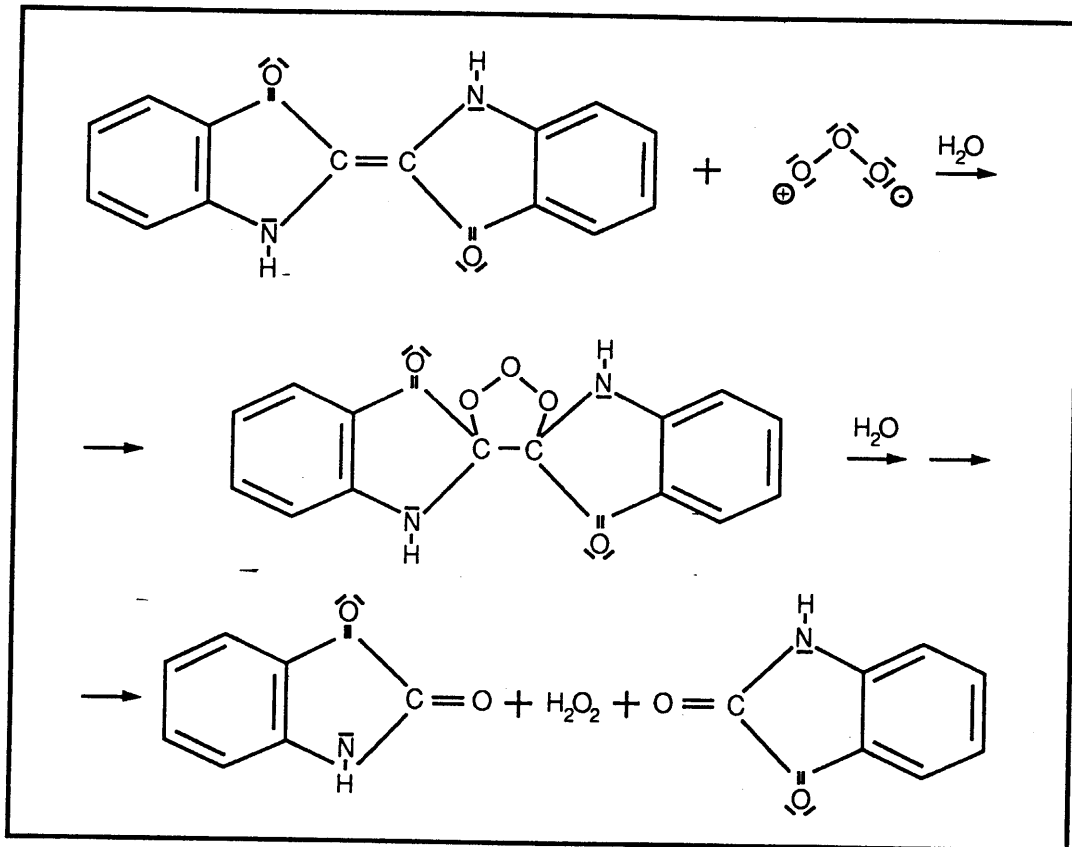

Fig. 1: Oxidation of indigo with O₃.

In other cases, oxidation of substances with little colouring can result in the first steps in coloured intermediate compounds, e.g. of the Wurster's red type, which, when subjected to additional oxidation, can be decolourized again. In general, in addition to the dyestuffs, waste water often contains substances which are more or less easily oxidisable, in most cases organic. The lower the organic contamination in the water, the less ozone is needed to decolourize dyestuffs, because the chromophore structural unit is destroyed by only brief contact with small quantities of ozone. In the case of waste waters which are subjected to low organic contamination - i.e. COD values from 150 to 200 mg/l - the colours yellow (436 nm), red (525 nm) and blue (620 nm) can be decolourized by 80% to 90% using low ozone consumption of approx. 70 mg/l and short reaction times of approx. 12 minutes, provided that in the untreated waste water initial specific colour intensity indicators of 10 m⁻¹ are present [4]. Substances which are problematical for environmental reasons were not found [5]. In the case of water with high organic contamination, pre-treatment is recommended to reduce the COD level. In the case of water with low ultraviolet transmission, additional exposure to ultraviolet radiation did not lead to any benefits, as was to be expected [6]. The results of laboratory and pilot tests are shown below, and with the help of these plans can be drawn up for large industrial projects. Results of an industrial application are shown, too.

2. Laboratory tests

By making use of laboratory tests, the feasibility of the decolourization and the necessary quantities of ozone can be determined, so that the appropriate values for a large industrial project can be established, as well as rough estimate of the associated capital and operating costs. Because a laboratory test can only be carried out with a special water sample, which for its part only represents a specific moment in time and is not necessarily typical of the variations which occur during normal use, it is necessary to ensure that as representative a sample as possible (e.g. composition of the individual substances and of the dyestuff classifications such as reactive dyestuffs, dispersion dyestuffs etc., COD contamination, pH value) is taken; if possible pilot tests should be carried out subsequent to the laboratory tests.

In principle, the combinations of O_3 , O_3/UV , H_2O_2/UV , O_3/H_2O_2 , O_3 with $pH > 9$ can be used. It is not possible to give details of the specific differences and advantages of the individual combinations depending on specific usage. The following example makes use of the results of treatment using O_3 .

Laboratory equipment is shown schematically in fig. 2

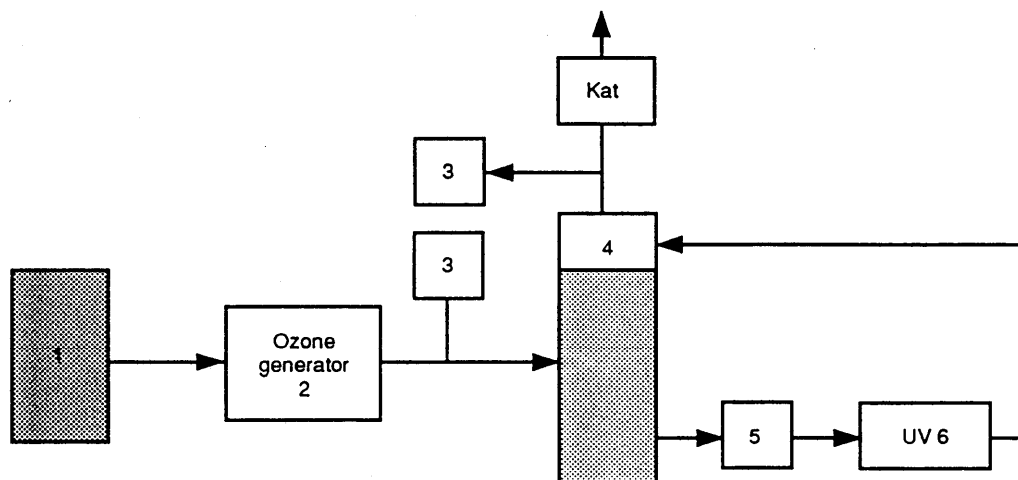

Fig. 2: Schematic diagram of WEDECO test equipment

The test equipment consists of a glass column (4) with a volume of 4 litres. A pump (5) is used to keep the liquid circulating continuously, so that it passes the UV reactor (6). Different sources of radiation are available, depending on the test which is to be carried out. The oxygen-ozone mixture is introduced into the reverse current [oxygen supply (1), ozone generator (2)] and removed via the top of the column. The degree of transformation of the ozone is effected by means of ozone measuring equipment (3). Oxidation agents can be added continuously or at intervals. Samples are taken at intervals.

Table 1 summarises a few of the important data provided by the laboratory equipment.

	Unit	Value	Comments
Gas volume flow	l/h (STP)	30	
Ozone concentration	g/m ³ (STP)	100	
Water volume	litre	approx. 3.5	
Temperature	°C	22	
Pressure	bar abs.	1	
UV energy	W	6	Hg low pressure lamp
	W	150	Hg medium pressure lamp

Table 1: Characteristic data provided by the WEDECO laboratory equipment (STP: 25°C; 1013 m bar)

In the case of low COD values in the water, low ozone consumption is expected for decolourization, and the exact amount is dependent of structure of the dyestuffs. Fig. 3 shows the results of ozone treatment of waste water caused by the dyeing of paper [6]. The COD was reduced to approx. 120 mg/l by means of physical pre-treatment processes; however, the red colouring could only be removed by means of oxidation treatment using ozone. It is seen that a reduction of colour in the case of 525 nm (red) from 21 m⁻¹ to 5 m⁻¹ (colour, measured as extinction at a certain the wavelelength divided by the cell length, derived from Lambert-Beer's law $\frac{E}{d} = E \cdot C$, where E = extinction, d = cell length, E = molar extinction coefficient, C = concentration of a compound. Therefore colour measurement has the dimension m⁻¹) is achieved with an ozone input of approx. 10 g ozone per m³ of waste water. This colour of 5 m⁻¹ in the case of 525 nm (red) is under discussion according to the amendment to appendix 38 framework waste water VwV (FRG). The COD value is affected to a far lesser extent (approx. 25% reduction, from 120 mg/l to approx. 90 mg/l.)

With increasing COD values in waste water, the ozone consumption needed for significant decolourization also normally rises, because the COD is also affected to a certain extent, cf. figures 3 and 4. Even in the case of high COD values in untreated water, it can be observed that the decolourization process takes place faster than the reduction in COD, cf. fig. 5.

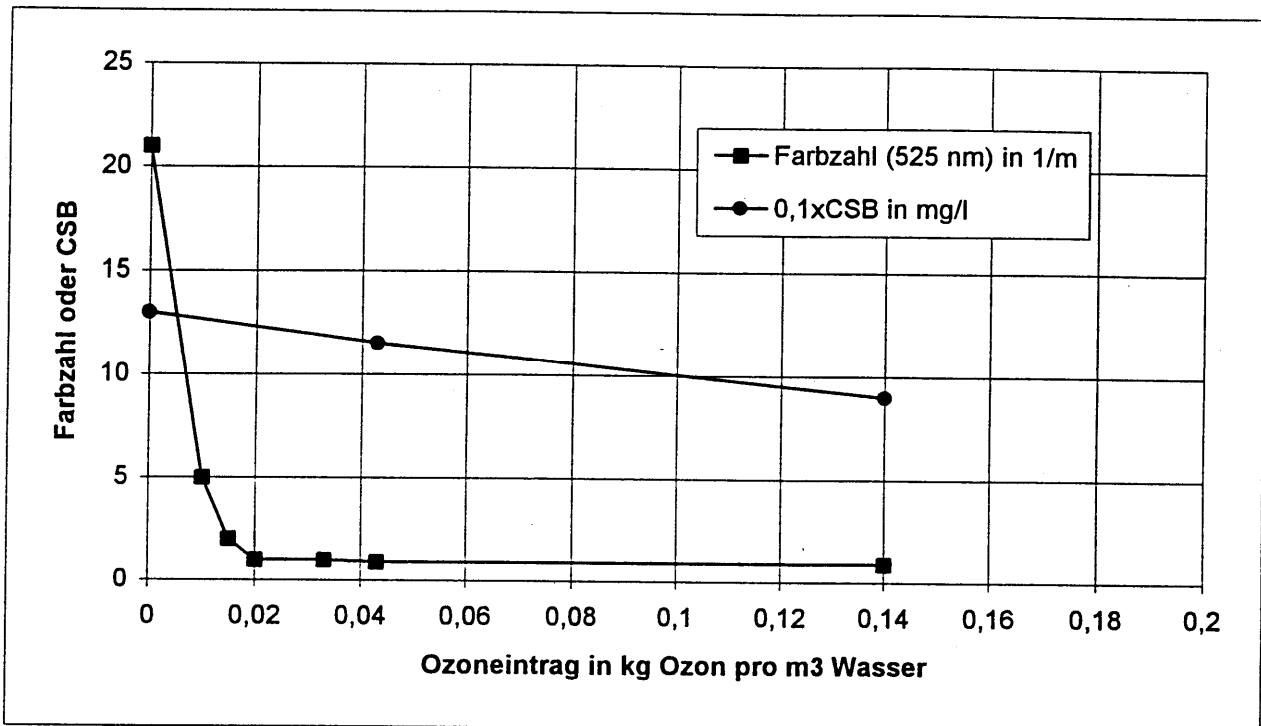

Fig. 3: Effect of ozone input (kg of ozone per m³ of water) on the decolourization (Colour at 525 nm, see text) and on the COD in physically pre-treated waste water resulting from paper dyeing.

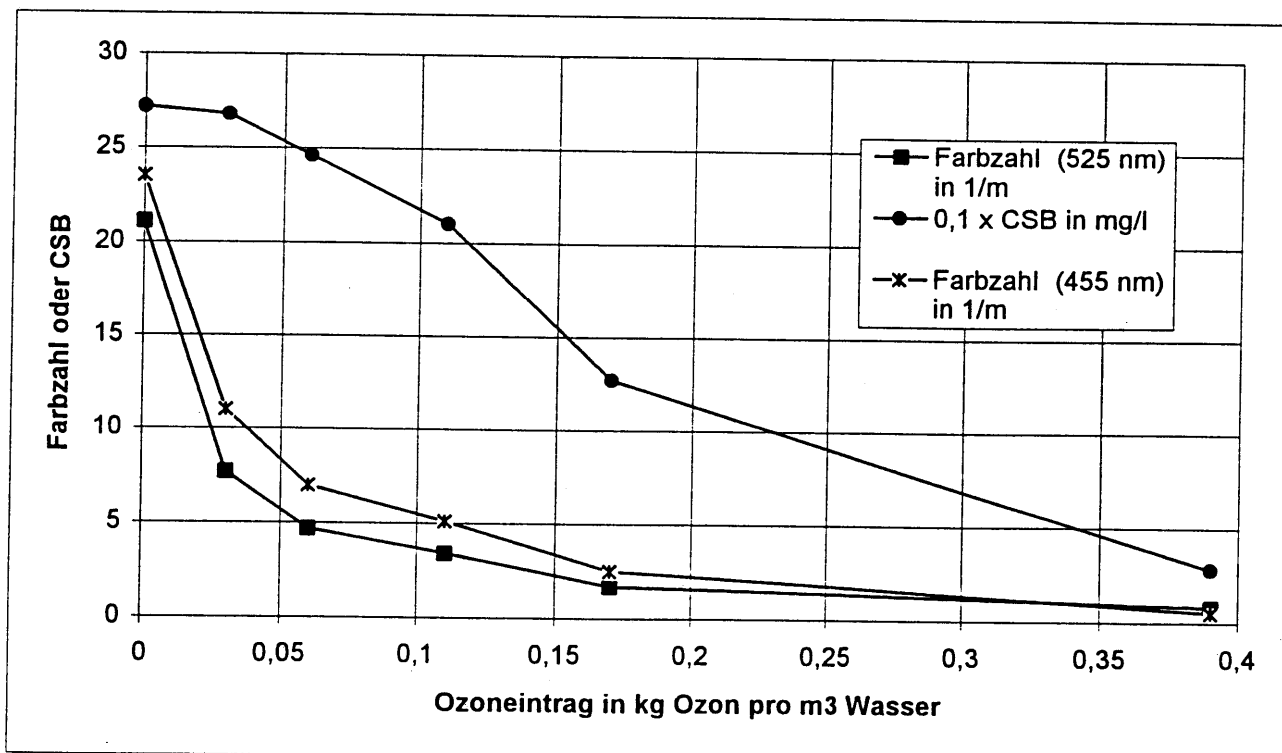

Fig. 4: Effect of ozone input (kg of O₃ per m³ of water) on the decolourization (Colour at 525 and 455 nm, see text) and on the COD in industrial waste water resulting from carpet dyeing.

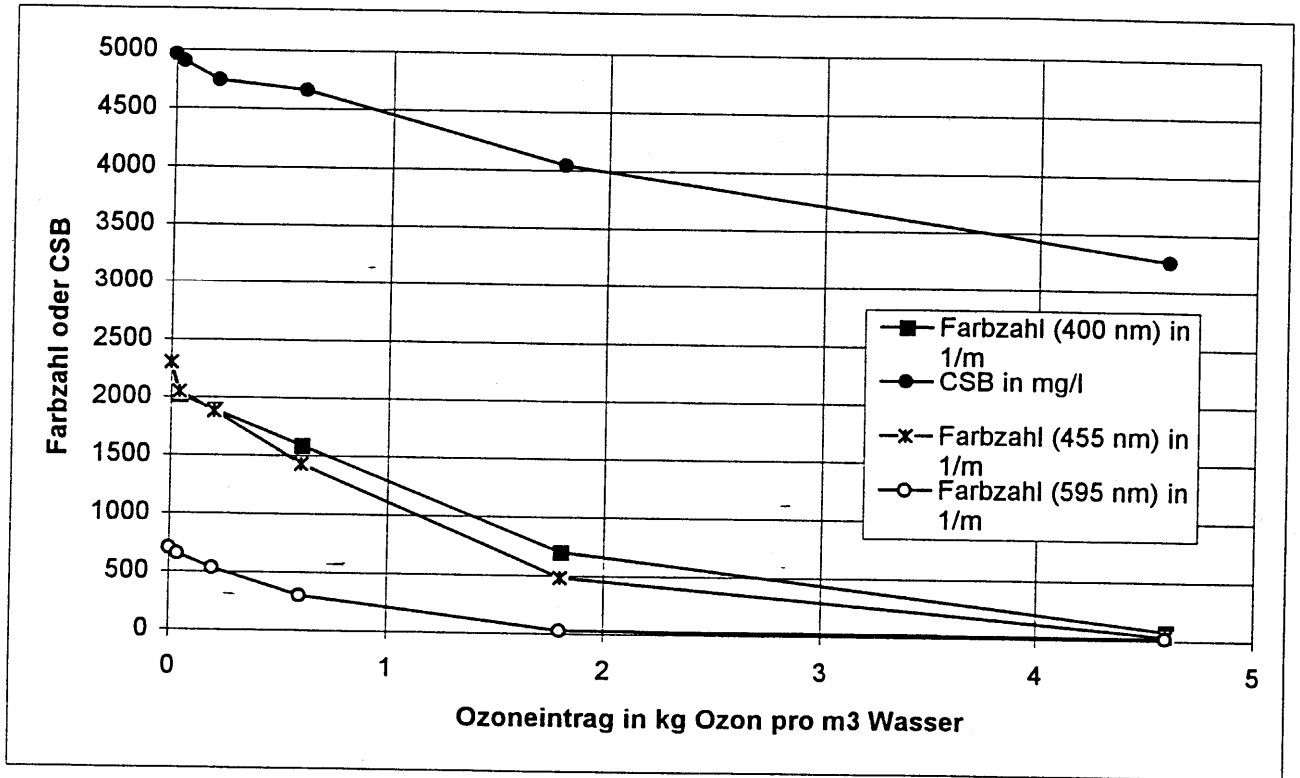

Fig. 5: Effect of ozone input (kg of ozone per m³ of water) on the decolourization (Colour at 400 nm, 455 nm and 595 nm, see text) and on the COD industrial waste water resulting from dyestuff manufacture.

3. Test on a semi-industrial scale [6]

In order to examine the influence of the concentration of dyes and other substances in the waste water, as well as to be able to make statements on the process technology, a field test lasting several months was carried out in a dyehouse.

The aim of the test was to achieve a clear removal of colour and to check the decomposition of COD which took place in parallel. The equipment is fed with the different qualities of waste water which occur: overall waste water, rinsing water from the dyeing machines, the range of dyes, and a sample of synthetic waste water.

An ozone/UV combination unit was installed on-site to permit the trial phase to be carried out. In this case, a combination unit was used with an ozone production up to 70 g/h. The unit is fitted with a UV reactor which can be operated at two different levels, depending on requirements, cf. fig. 6.

In order to examine the effects of the UV radiation, the unit was at times fitted with the 2 kW medium pressure emitter. Because the results gave no indication of a positive effect as a result of the exposure to UV radiation, the remaining tests were carried out without the use of UV energy. The unit operates with a water circulation system, which enriches the ozone in the medium. A pressure booster pump creates a system pressure of 5 bar abs., and the mixture of oxygen-ozone is added by means of an injector. The ozone is absorbed in the pressurised container. Undissolved oxygen and any remaining undissolved ozone are separated from the water phase in the degasifying container. The result is that the UV reactor is supplied with water which is free of gaseous bubbles. Following treatment, the separated gas, mainly damp O_2 , can again be used to produce O_3 . This means a considerable reduction in operating costs.

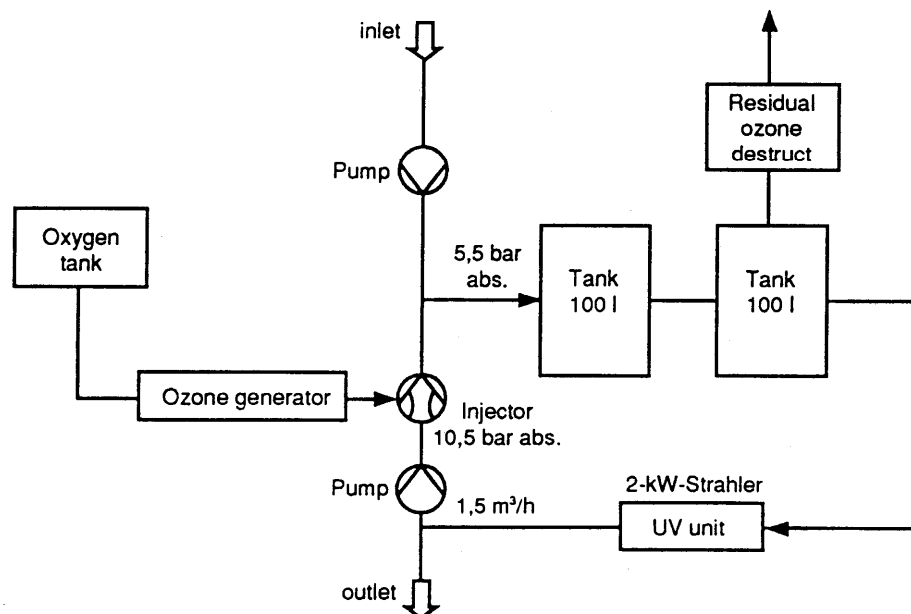

Fig. 6: Schematic diagram of the WEDECO pilot unit

The results with regard to the consumption of ozone provided as a result of laboratory tests were, in general, confirmed. Nearly independent of the starting colour within the test series a decolourization of 80 % and more was achieved. At the same time, the COD decreased by approx. 30 - 40 %. The results of the COD and decolourization measurements for the waste water are given in tables 2 and 3. The residence times were between 18 and 54 minutes.

Test no.	Water volume flow	Residence time	COD inlet	COD outlet	Rate of COD decomposition	Decomposition of COD	Factor
	[l/h]	[min]	[mg/l]	[mg/l]	[g/h]	[%]	[gO ₃ /gCOD]
18	200	54	570	425	29,0	25,4	2,4
20	200	54	698	574	24,9	17,8	2,8
15	300	36	516	325	57,3	37,0	1,2
19	300	36	746	497	74,7	33,4	0,9
17	350	31	517	463	18,9	10,4	3,7
14	400	27	941	719	88,8	23,6	0,8
16	400	27	807	545	104,8	32,4	0,7
13	600	18	530	368	97,2	30,6	0,7
26	400	27	409	252	62,8	38,4	1,1
27	300	36	719	440	83,7	38,8	0,8
Long-term test							
8	300	36	580	348	69,3	40,0	1,0
16	300	36	447	273	52,2	38,9	1,3
24	300	36	1146	594	165,6	48,2	0,4
32	300	36	1205	717	146,4	40,5	0,5
40	300	36	731	517	64,2	29,3	1,1
48	300	36	1265	795	141,0	37,2	0,5
56	300	36	1023	452	171,3	55,8	0,4
66	300	36	711	513	59,4	27,8	1,2
medium value for long-term test		36	889	526	109	40	0,8

Table 2: Details of COD decomposition in pilot tests in a dyehouse (for parallel decolourization, see table 3).

Test no.	Colour at 436 nm in [m^{-1}] (see text)			Colour at 525 nm in [m^{-1}] (see text)			Colour at 620 nm in [m^{-1}] (see text)		
	Inlet	Outlet	Decolouriza- tion [%]	Inlet	Outlet	Decolouriza- tion [%]	Inlet	Outlet	Decolouriza- tion [%]
18	129,5	12,7	90,2	102,7	8,2	92,0	15,4	1,8	88,3
20	66,6	5,6	91,6	30,0	2,2	92,7	4,9	0,5	89,9
15	100,0	23,0	77,0	181,4	34,9	80,8	39,2	7,3	81,4
19	58,6	12,4	78,8	27,0	5,9	87,1	4,5	1,2	73,3
17	129,5	26,3	79,7	102,7	19,3	81,2	15,4	3,7	76,0
14	131,3	31,6	75,9	108,7	23,1	78,7	27,5	5,8	78,9
16	79,7	25,0	68,6	42,9	13,8	67,8	23,7	6,8	71,3
13	78,3	9,3	88,1	26,4	2,0	92,4	4,5	0,5	88,9
26	29,1	5,7	80,4	21,4	2,9	86,4	42,9	5,2	57,9
27	92,7	8,6	90,7	45,0	3,4	92,4	37,6	1,9	94,9
Average value	98,5	16,0	82	68,8	11,6	83	21,6	3,5	84

Table 3: Measurement of the removal of colour during pilot tests in a dyehouse (for parallel COD decomposition, see table 2).

The effect of the reaction time was studied by operating the unit with different volume flows. In the case of this waste water, which was characterised by high variations in rate, the reaction time was not a relevant factor. However, a reaction time of 30 minutes seemed to be sufficient.

For the overall flow of waste water, which showed low contamination by colour (DFZ < 61,2 m^{-1} at 436 nm) and a low volume of oxidizable compounds (COD < 244 mg/l O₂), it was possible to achieve shorter reaction times (8 - 14 mins). While the colour decomposition varied between 74% and 95%, the COD - as a result of the short reaction time - was only decomposed by a maximum of 36%.

To summarise, it can be said that oxidation of the dyestuffs in the different waste water flows of a textile dyeing plant was carried out successfully using ozone. Depending on the degrees of contamination of the water with COD and dyestuffs, in long-term operation colour between 10 and 20 m^{-1} were achieved without difficulty. The specific ozone consumption in water whose composition is constantly changing is extremely difficult to determine. The less the waste water is contaminated with oxidizable compounds (COD), the better the decomposition of the dyestuffs. Shorter reaction times are required, and, because the effect of the COD decomposition decreases, lower quantities of O₃ are needed.

4. Results of large-scale ozone treatment

The principle of ozone oxidation with short reaction times is used at the Ochtrup clarification plant for the additional treatment of coloured waste water resulting from dyeing processes in textiles. In order to increase the effectiveness of the ozone treatment stage, the flows of textile and communal waste water which had previously been treated together using ozone were separated from each other, cf. fig. 6 [6, 7]

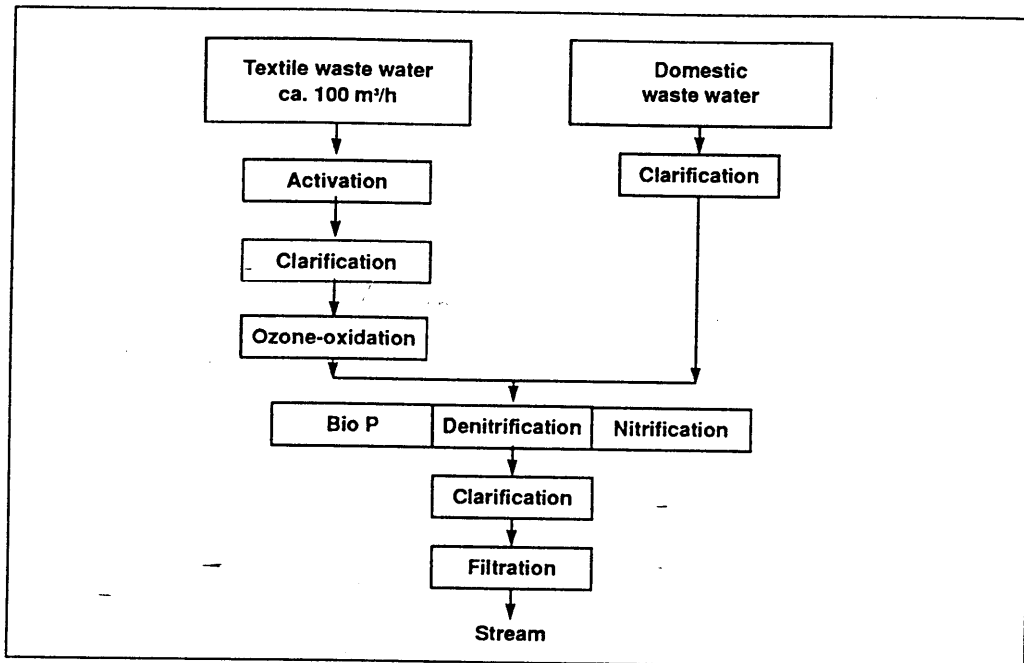

Fig. 7: Flow chart for the Ochtrup clarification plant

There is an average of approx. 100 m³/h of textile waste water, while approx. 300 - 400 m³/h of communal waste water is introduced into the joint biological treatment process, where the COD is removed to values of 65 mg/l.

In order to reduce the COD from approx. 1100 mg/l in textile waste water prior to ozonization, the waste water containing reactive dyestuffs is first pre-treated biologically. The water entering the ozone stage has a COD value of approx. 600 mg/l, which is only slightly reduced - by approx. 5 - 8% - by the ozone treatment. On the other hand, the decomposition of dyestuffs at wavelengths of 436 nm, 525 nm and 620 nm is, at 60 - 80% - considerably higher, cf. table 4. In this case, approx. 8.5 kg/h of ozone are used. Table 5 provides some data relating to the ozone stage. Up to 160 m³/h of water can be pumped hydraulically through the plant, and the reaction time in the reaction containers is then approx. 12 minutes. The aim of the ozonization is not to achieve particular COD or specific colour values, but to achieve a marked decolourization and to improve the biological degradability of the substances in the flow of textile waste waters, which is of benefit to the communal clarification plant. The observed rise in the BOD (5 days) of approx. 10% (after ozonization) is even more marked with additional tests carried out here with an approximately 30% increase [8]. This effect was also confirmed in tests at other sites [9].

Parameters	Inlet O ₃ plant	Outlet O ₃ plant	Relative change in %
Colour in m ⁻¹ [8]			
yellow (436 nm)	31	11,5	- 61
red (525 nm)	24,9	6,3	- 74
blue (620 nm)	23,1	4,6	- 80
COD in mg/l	600 - 700	560 - 650	- (5 bis 8)
BOD ₅ in mg/l	130	140 - 150	+ 10
pH	8 - 9	~ 8	-
AOX in µg/l [8]	268	104	- 61
Polyvinyl alcohol in mg/l [8]	69	37	- 46

Table 4: Average results of of the ozone stage in the Ochtrup clarification plant

Parameters	Unit	Comments
Ozone capacity	up to 12 kg/h ozone from oxygen	approx. 60 % O ₂ saving oxygen due to circulating
Waste water volume flow	up to 160 m ³ /h of biologically pre-treated textile waste water	The volume flow which is fed in can be controlled by the operator of the clarification plant
Reaction time	12 - 30 minutes	according to set volume flow

Table 5: Technical data of the ozone stage

5. Literature

- [1] M. Matsui, K. Shibata, H. Muramatsu: "Ozone Fading of Dyes", Proceedings of 11th Ozone World Congress: "Ozone in Water and Waste Water Treatment", Vol. 1, pp S-7-87 to S-7-90, San Fransico 1993.
- [2] J. Hoigné, H. Bader: "Bestimmung von Ozon und Chlordioxid mit der Indigo-Methode", Vom Wasser 55 (1980) 261-279.
- [3] E. Gilbert, J. Hoigné: "Messung von Ozon in Wasserwerken, Vergleich der DPD-und Indigomethode", Gas Wasserfach, Wasser Abwasser 124 (1983) 527-531.
- [4] H.-U. Baldes, J. Becker: "Ozone Treatment of Textile and Dye-House Wastes", Proceedings of 11th Ozone World Congress:"Ozone in Water and Waste Water Treatment", Vol. 1 pp S-10-76 to S-10-83, San Fransico 1993.
- [5] F. U. Gähr:"Oxidativer Abbau von Reaktivfarbstoffen durch Ozon", Dissertation, Institut für Textilchemie der Universität Stuttgart, 1992.
- [6] C. Jonas, O. Leitzke: "AOX-Elimination und Entfärbung von Industrieabwässern", Colloquium Produktionsintegrierter Umweltschutz, Bremen 1993.
- [7] K. Schwämmlein, C. Jonas: " Abwasser- und Prozeßwasserbehandlung mit Ozon und kombinierten Oxidationsverfahren", Ozon-Symposium der Fa. MG Oxhydrique, Brüssel 1995.
- [8] K. Helle: " Untersuchungen zur Textilabwasserbehandlung mit Ozonbehandlung, Pulverkohledosierung und Mehrschichtfiltration auf der Kläranlage Ochtrup", Bericht des Instituts für Siedlungswasserwirtschaft der RWTH Aachen, Aachen 1994.
- [9] M. Kolb, B. Müller, B. Funke: " Entfärbung von textilem Abwasser mit Ozon", Vom Wasser, 69 (1987) 217-223.